

# User Manual

DuraFon-UHF-HC

Durable, Long-Range, Dual Mode Radio Phone



## Table of Contents

---

Safety Instructions.....	4
General Safety Instructions .....	4
Product Safety Instructions .....	4
Battery Safety Instructions .....	6
Regulatory Information .....	7
Equipment Checklist .....	11
Handset Illustration .....	12
Handset Features .....	14
Basic Handset Features.....	14
Additional Handset Features .....	16
Administrator Features (Register to PRO base).....	19
Charger Illustration.....	20
Charger Features .....	21
Getting Started .....	22
Handset and Charger Installation .....	22
Basic Operations.....	23
Operation Modes.....	23
<i>Base Operation Modes</i> .....	23
<i>Handset Operation Modes</i> .....	23
Menu Tree (Register to PRO base only).....	24
Making a Telephone Call.....	25
Making an 2-Way/ Intercom Call .....	25
<i>Handset to Handset Calls</i> .....	25
Making a Broadcast via 900MHz .....	26
<i>Handset to Handset Calls</i> .....	26
Making a Broadcast via UHF .....	27
<i>Handset to UHF walkie-talkie</i> .....	27
Redial .....	27
Receiving a Telephone Call .....	28
Receiving an Intercom Call .....	28
Ending a Call.....	29
Adjusting Receiver (Earpiece) Voice Volume .....	29
Adjusting Speaker Volume.....	29
Placing a Call On Hold .....	30
Mute .....	30
Do Not Disturb (Silent Ring).....	30
KeyGuard .....	31

To View Missed Call(s) .....	31
To Call back from Call Log .....	31
Battery Recharge and Replacement .....	32
Walkie-Talkie Mode .....	33
Advanced Operations .....	34
Handset Registration (Register to PRO base only).....	34
Advanced Registration (Register to PRO base only) .....	35
Handset Group Subscription.....	37
Call Transfer (Register to PRO base only) .....	37
3-Way Conferencing (Register to PRO base only).....	38
Base Select (Register to PRO base only ) .....	39
Call Waiting (Register to PRO base only) .....	39
Auto Attendant (AA) (Register to PRO base only) .....	40
AA Configuration by Administrator (Register to PRO base only).....	41
Change AA Parameters (Register to PRO base only) .....	42
Line Dedication (Register to PRO base only) .....	43
Line Selection (Register to PRO base only) .....	43
Change System and Line Settings by Admin (Register to PRO base only) .....	44
Phonebook Operations (Register to PRO base only) .....	45
Programmable PBX Options (Register to PRO base only).....	49
Broadcast through PBX (Register to PRO base only) .....	50
UHF Frequencies and Codes .....	52
Menu Operations (Register to PRO base only).....	54
Technical Specifications.....	60
Index .....	62
FCC Part 68 Statement .....	64

# Safety Instructions

**Caution:** *Your wireless telephone gives you freedom and flexibility to stay in touch while you move around. However, when using your phone equipment, safety instructions should be followed to avoid the risks of fire, electric shock, injury to person, and damage to property.*

## General Safety Instructions

1. When using your wireless handset, ensure your safety and the safety of others:
  - a. Always watch where you are walking and standing.
  - b. Don't let a phone call distract you from working safely.
  - c. If power goes out, the phone won't work. A backup power source or landline is recommended.
2. In an emergency:
  - a. If an emergency occurs, dial the emergency phone number. Remember: if you are in an area where your phone does not have a clear signal from the base, it is highly probable that the call may not go through. Locate the nearest landline telephone or other communications device to call for help.
  - b. Emergency calls may not automatically provide emergency personnel with your name, phone number or location.
3. Notice to hearing aid users: This phone system is compatible with inductively coupled hearing aids.
4. Notice to cardiac pacemaker users: Preliminary studies done by the US FDA and others have shown that, although interference to the implanted cardiac pacemaker may occur when operating very closely, wireless telephones "do not seem to pose a significant problem for pacemaker wearers." However, until more is known, the FDA suggests that people with pacemakers may want to take precautions when using or carrying a wireless telephone to ensure that there is ample distance between the telephone and the pacemaker. Do not carry the handset in a breast pocket. If you have any reason to suspect that interference is taking place, turn off your handset immediately.

## Product Safety Instructions

1. Read and understand all instructions.

2. Follow all warnings and instructions including those marked on the product.
3. Changes or modifications to this product not expressly approved by the manufacturer will void the warranty and the FCC authorization to operate the equipment. Use only manufacturer-provided accessories.
4. Do not use the telephone near water. Never spill liquid of any kind on this product.
5. Unplug the product from the wall telephone jack and power outlet before cleaning. Do not use liquid or aerosol cleaners. Use a damp cloth for cleaning.
6. Do not place this product on an unstable cart, stand, or table. The product may fall and cause personal injury or damage to the product or other property.
7. In the event of a power outage, your handset charger will not recharge the handset battery, and the base station will not allow you to make an outgoing call or take an incoming call. Both the charger and the base station require electricity for operation. You should have a telephone that does not require electricity available for use during power outage, or have a temporary backup power supply.
8. Slots or openings in the product's housing are provided for ventilation. These openings must not be blocked or covered. Placing the product on a bed, carpeting, or other similar surface may block these openings and should be avoided. This product should never be placed near or over a radiator or heat register or in a built-in installation unless proper ventilation is provided.
9. Never push objects of any kind into this product through housing slots/openings as they may damage the product, touch dangerous voltage points, or short-circuit parts that could result in fire, electric shock, or injury.
10. This product should be operated only from the type of power source indicated on the label. If you are not sure of the type of power supply to your home, consult your dealer or local power company.
11. Do not overload wall power outlets or extension cords as this may result in fire or electric shock.
12. To avoid electric shock or burn, do not disassemble this product. Send this product to an authorized service center when service or repair work is required. Call Customer Service for locations near you. Opening or removing covers may expose you to dangerous voltages, electrical currents, or other risks. Incorrect reassembling of the product may cause electric shock when the product is subsequently used.
13. Avoid using the product during a storm. There may be a risk of electric shock from lightning.
14. Do not place the product where persons can step, trip, or fall on it.

15. Do not place conductive objects over or near the antenna.
16. Do not use the product to report a gas leak while in the vicinity of the leak.
17. Do not install the base station or the handset charger near microwave ovens, radios, TV sets, speakers, or other electrical equipment. These appliances may cause interference to the product or experience interference from the product.
18. Unplug the base station or the charger adaptor from the power outlet and refer to an authorized service center under the following conditions:
  - a. Liquid has been spilled into the product.
  - b. The power supply cord or plug is damaged or frayed.
  - c. The product has been exposed to rain or water.
  - d. The product does not operate normally when following the operating instructions.
  - e. The product has been dropped or housing has been damaged.
  - f. The product shows a distinct change in performance.

## **Battery Safety Instructions**

1. Use only manufacturer-approved Li-ion rechargeable batteries and charger. Do not use other types of rechargeable batteries or non-rechargeable batteries. The batteries could short-circuit and damage the battery enclosure, causing a hazardous condition.
2. Follow the charging instructions in this manual and instruction labels and markings in the handset and charger compartments.
3. Batteries must be recycled or disposed of properly. Do not dispose of batteries in a fire, as the cells may explode.
4. Do not dispose of batteries in municipal waste. Check with local codes for disposal instructions.
5. Exercise care in handling batteries. Conductive materials such as rings, bracelets, keys, pocketknives, and coins may cause the battery or conductive material to short-circuit, overheat, and cause burns or fire.
6. Do not expose batteries to rain or water.
7. Do not open or mutilate the battery. The released electrolyte is corrosive and may cause injury to eyes or skin. The electrolyte may be toxic if swallowed.
8. During charging, the battery heats up. This is normal and is not dangerous.

# Regulatory Information

## **DuraFon-UHF-HC (SPR-922U1)**

**FCC ID: A8J-SPR922U1**

This device complies with Part 15 of the FCC Rules. Operation is subject to the following two conditions:

- 1) this device may not cause harmful interference, and
- 2) this device must accept any interference received, including interference that may cause undesired operation.

Privacy of communications may not be ensured when using this phone.

## **Base Station**

### **Federal Communication Commission Interference Statement**

This equipment has been tested and found to comply with the limits for a Class B digital device, pursuant to Part 15 of the FCC Rules. These limits are designed to provide reasonable protection against harmful interference in a residential installation. This equipment generates, uses, and can radiate radio frequency energy and, if not installed and used in accordance with the instructions, may cause harmful interference to radio communications. However, there is no guarantee that interference will not occur in a particular installation. If this equipment does cause harmful interference to radio or television reception, which can be determined by turning the equipment off and on, the user is encouraged to try to correct the interference by one of the following measures:

- Reorient or relocate the receiving antenna.
- Increase the separation between the equipment and receiver.
- Connect the equipment to an outlet on a circuit different from that to which the receiver is connected.
- Consult the dealer or an experienced radio/TV technician for help.

FCC Caution: Any changes or modifications not expressly approved by the party responsible for compliance could void the user's authority to operate this equipment.

This device complies with Part 15 of the FCC Rules. Operation is subject to the following two conditions: (1) This device may not cause harmful interference,

and (2) this device must accept any interference received, including interference that may cause undesired operation.

**IMPORTANT NOTE:**

**FCC Radiation Exposure Statement:**

This equipment complies with the FCC radiation exposure limits set forth for an uncontrolled environment. This equipment should be installed and operated with a minimum distance of 20cm between the radiator and your body.

This transmitter must not be co-located or operating in conjunction with any other antenna or transmitter.

**Industry Canada Statement:**

This device complies with RSS-210 of the Industry Canada rules. Operation is subject to the following two conditions:

(1) This device may not cause harmful interference, and (2) this device must accept any interference received, including interference that may cause undesired operation.

**IMPORTANT NOTE:**

**Radiation Exposure Statement:**

This equipment complies with IC radiation exposure limits set forth for an uncontrolled environment. This equipment should be installed and operated with minimum distance 20cm between the radiator and your body.

This device has been designed to operate with an antenna having a maximum gain of 1.5 dBi. Antennae having a higher gain are strictly prohibited per regulations of Industry Canada. The required antenna impedance is 50 ohms.

**Portable Handset**

**Federal Communication Commission Interference Statement**

This equipment has been tested and found to comply with the limits for a Class B digital device, pursuant to Part 15 of the FCC Rules. These limits are designed to provide reasonable protection against harmful interference in a residential installation. This equipment generates, uses, and can radiate radio frequency energy and, if not installed and used in accordance with the instructions, may cause harmful interference to radio communications. However, there is no guarantee that interference will not occur in a particular installation. If this equipment does cause harmful interference to radio or television reception, which can be determined by turning the equipment off and on, the user is encouraged to try to correct the interference by one of the following measures:



- Reorient or relocate the receiving antenna.
- Increase the separation between the equipment and receiver.
- Connect the equipment to an outlet on a circuit different from that to which the receiver is connected.
- Consult the dealer or an experienced radio/TV technician for help.

FCC Caution: Any changes or modifications not expressly approved by the party responsible for compliance could void the user's authority to operate this equipment.

This device complies with Part 15 of the FCC Rules. Operation is subject to the following two conditions: (1) This device may not cause harmful interference, and (2) this device must accept any interference received, including interference that may cause undesired operation.

**IMPORTANT NOTE:**

**Radiation Exposure Statement:**

This equipment complies with FCC radiation exposure limits set forth for an uncontrolled environment. End users must follow the specific operating instructions for satisfying RF exposure compliance. To maintain compliance with FCC RF exposure compliance requirements, please follow the operation instructions as documented in this manual.

This transmitter must not be co-located or operating in conjunction with any other antenna or transmitter.

**Industry Canada Statement:**

This device complies with RSS-210 of the Industry Canada rules. Operation is subject to the following two conditions: (1) This device may not cause harmful interference, and (2) this device must accept any interference received, including interference that may cause undesired operation.

**IMPORTANT NOTE:**

**Radiation Exposure Statement:**

This equipment complies with IC radiation exposure limits set forth for an uncontrolled environment. End users must follow the specific operating instructions for satisfying RF exposure compliance. To maintain compliance with IC RF exposure compliance requirements, please follow operation instructions as documented in this manual.

This device has been designed to operate with an antenna having a maximum gain of 1.5dBi. Antenna having a higher gain is strictly prohibited per regulations of Industry Canada. The required antenna impedance is 50 ohms.

# Equipment Checklist

In a Handset package, please find the following components:

1. Handset x 1
2. Handset Antenna x 1
3. 2300mA Li-ion Battery x 1
4. Charger x 1
5. Charger AC/DC Adaptor x 1
6. Clip Fastener x 1
7. Belt Clip x 1
8. Quick Guide and Warranty Card

# Handset Illustration

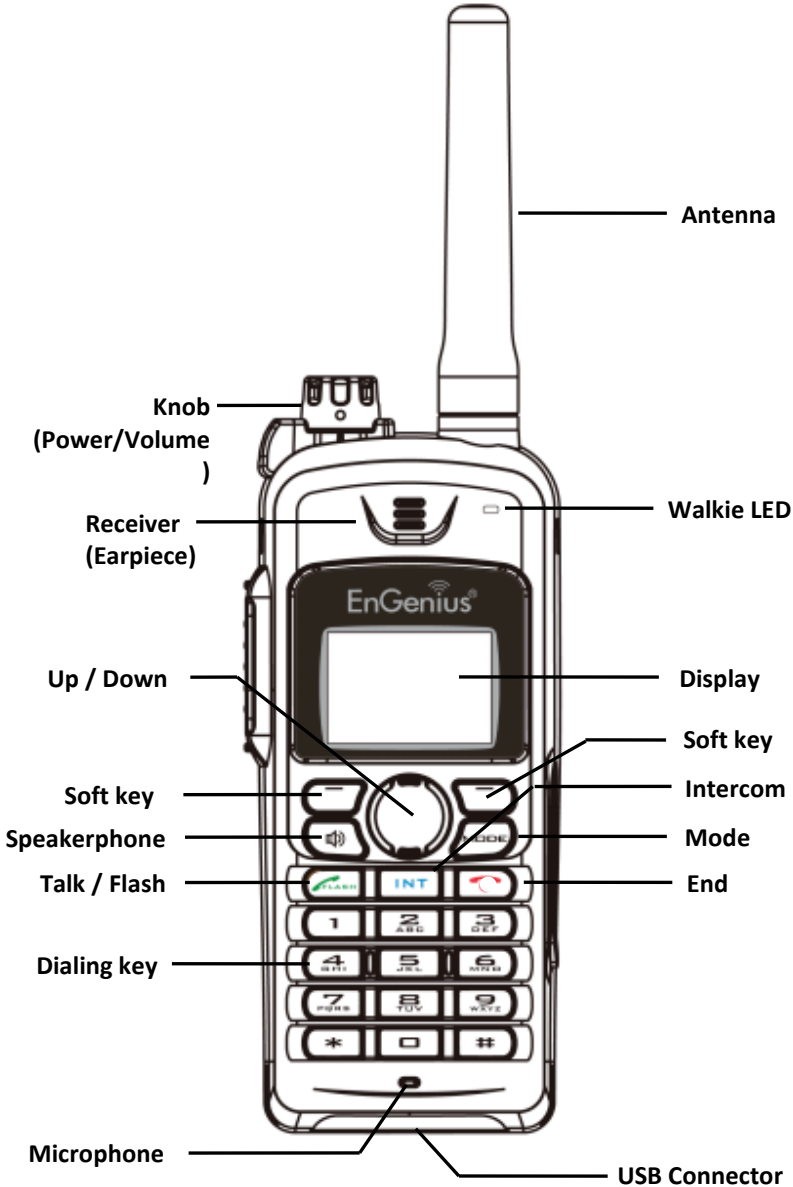

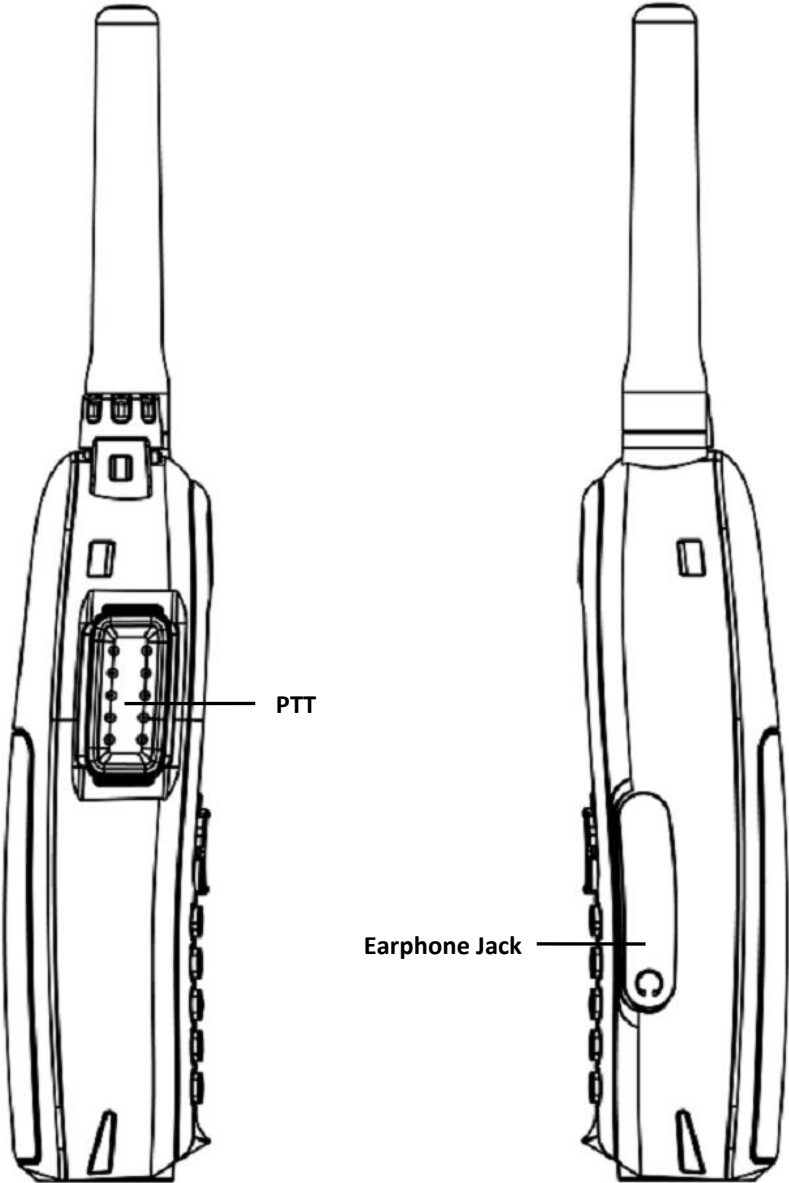

# Handset Features

## Basic Handset Features

### 1. 4-line LCD (Liquid Crystal Display)

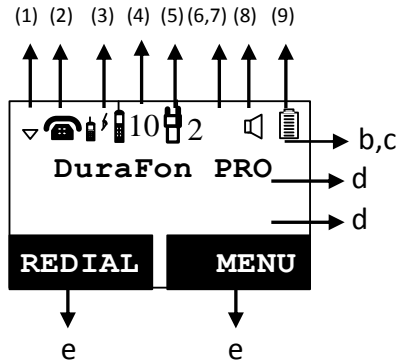



- The LCD display has LED (Light Emitting Diode) backlighting.
- The 1<sup>st</sup> line of the LCD consists of icons.
- Icons from left to right:
  - RSSI (Receive Signal Strength Indicator; 900 MHz only)**  
During a call, the number of bars is proportional to the radio signal strength received.
  - Call In-progress (ON/OFF-Hook)**  
Indicates if phone line mode is active
  - Intercom In-progress**  
Indicates if Intercom mode is active
  - Handset ID**  
Displays a handset icon and a 2-digit handset ID
  - Channel Number in Walkie**  
Indicates the channel (1–5) selected
  - Two-Digit Address Index**  
Shows address index when viewing contents of the call logs.
  - Line Indicator**  
Indicates the number of the line being accessed by the handset.
  - Speaker Phone**  
Indicates if speaker phone is active
  - Battery Strength**
    - Number of bars is proportional to the amount of battery time

remaining.

- Indicates charging when in charger cradle.

- d. The second and third lines of the LCD, maximum 14 characters each, display status, message, menu selections, or user-editable alphanumeric characters.
  - e. The last line displays the left and right soft keys.
2. Ringer
- a. Rings to an incoming call.
  - b. Distinctive alert sounds indicate various events:
    - Single beep: successful key entry
    - Double beep: failed operation or invalid key entry; also, power on/off
    - Periodic 1-Long-2-Short beeps (every 1 minute): low battery warning
    - Periodic Long Series of beeps (repeat every 30 seconds): on-hold call alert



3. TALK/FLASH 
- a. Places or answers a telephone or intercom call
  - b. Sends a flash signal to phone line to retrieve a dial tone after the call ends, or to perform the call waiting feature provided by local phone companies during a call.
  - c. Enables/disables speakerphone when held for one second.

4. SPEAKERPHONE 
- Press to enable/disable the speakerphone during incoming, outgoing or intercom calls.

5. 2-WAY INTERCOM 
- Places an intercom call to another handset ID or group ID (**group paging**). Intercom calls are digital, full-duplex, and are conducted without the assistance from the base.

6. PTT (Push-to-Talk)
- a. Activate half-duplex broadcasting via UHF (ultra high frequency) band or 900MHz band
  - b. Press the Mode key repeatedly to set the desired channel (1–5) in advance.

7. Left/Right Soft Keys 
- Make menu selection.

8. Up/Down Key
  - a. Scroll through records and menu selections.
  - b. Adjust receiver voice volume when in Talk mode.
  
9. END Key ()
  - a. Ends a call.
  - b. Leaves current menu operation; reverts one level.
  
10. MODE Key ()
  - a. Enter UHF 2-way radio operation setting.
  - b. Setting channel/Frequency/Code/Microphone gain/VOX.
  
11. Walkie LED
  - a. Static red light: Transmitting.
  - b. Static green light: Receiving UHF signal
  - c. Blinking green light: Standby

## **Additional Handset Features**

1. Multiple Handset Registration (Register to PRO base)
  - a. Up to 90 handsets can be registered to a single base.
  - b. IDs 10 and 11 are the first two handset IDs assigned by the base and are designated “administrators.” Use an administrator handset to change base settings such as the greeting message and other administrative functions.  
Note: Unless necessary, it is better not to assign IDs 10 and 11 to DuraWalkie handsets.
  - c. IDs 01-07: Group IDs. Handsets can “subscribe” from the handset menu to group(s) and be paged when a landline caller or an intercom caller enters a group ID.
  
2. Ringer/Vibrator
  - a. Six ringer volume-levels (high/medium/low/vibrate/vibrate-then-ring/off)
  - b. Four ringer type selections
  
3. Caller ID  
Displays incoming call phone number and name on the LCD (needs caller ID service from local telephone company)



4. Call Waiting with Caller ID  
Displays 2<sup>nd</sup> incoming call information on the same phone line when 1<sup>st</sup> call is in progress (needs call waiting with caller ID service from local telephone company)
5. Name Tagging with Caller ID  
Match the caller ID with the phone book entries; once matched, the LCD screen will display the name or nickname instead of pure caller ID info (needs call waiting with caller ID service from local telephone company)
6. DND (Do Not Disturb, i.e., Silent Ring)
7. Three Call Logs
  - a. Called Log: Stores 10 phone numbers (up to 28 digits each) dialed most recently. Can perform last-number redial on all 10 numbers.
  - b. Received Call Log: Stores 10 entries (14-digit phone number, 14-character names, and time stamp). Needs caller ID service from local telephone company.
  - c. Missed Call Log: Stores 10 entries (14-digit phone number, 14-character names, and time stamp). Needs caller ID service from local telephone company.
  - d. Phone numbers and names can be saved to phonebook while in display.
8. KeyGuard
9. Dialing Prefix  
One access code can be programmed to be automatically prefixed to the dialed number. This code can include up to 14 digits, including pause(s), and can be appended when dialing from call logs, phonebook, or dial-and-send functionality.
10. Call Hold
  - a. Places call on hold
  - b. Battery hot swap: Change battery while call is on hold.
11. Mute
12. Phonebook
  - a. Capacity for 90 entries, each of which stores a phone number or handset ID (up to 28-digit) and name (up to 14-character)
  - b. Alphabetically sorted display and search
  - c. Dial from display

- d. In stand-by mode, enter the phone book by pressing the Up/Down scrolling key
  - e. Phone book transfer via air
    - Transfer one phonebook to one handset or to all registered handsets
    - Transfer all phonebooks to one handset or to all registered handsets
13. Key Tone
- a. Three key-tone volume levels (high/low/off)
  - b. Four key-tone type selections
14. Call Timer
- Displays call time duration for current call during and immediately after the call
15. Call transfer (Register to PRO base)
- a. Direct Transfer: transfer a telephone call to another handset without announcement.
  - b. Announced Transfer: speak to the destination handset before transferring a telephone call.
16. Call Conferencing (Register to PRO base)
- a. 2-handset, 1-line conferencing.
  - b. 1-handset, 2-line conferencing.
17. Line Selection (Register to PRO base)
- When this function is enabled from the handset menu, a handset user will be prompted to select from a list of available lines before making an outgoing call.
18. Programmable PBX (private branch exchange) options:
- a. Program frequently used PBX features into the DuraFon handset.
  - b. Up to 9 entries can be saved.
  - c. Once the feature codes are programmed, you can use those functions during a call by pressing **OPTION**.
19. Base Selection (Register to PRO base)
- When enabled from the handset menu, a handset user can manually select the nearest base before making an outgoing call.

## Administrator Features (Register to PRO base)

Handsets 10 and 11 are designated administrators. Both have the same authority to perform base station administrative functions from their handset menus. No password is required.

1. DTMF and Pulse dialing support (For DuraFon PRO only)
  - a. From an administrator handset (Handset 10 or 11), press **MENU** — **9** — **1** — enter base ID (00–07) — **1** to select Tone or Pulse dialing mode.
  - b. The default setting is Tone dialing.
  
2. Administrator programmable Flash key timing (For DuraFon PRO only)
  - a. From an administrator handset (Handset 10 or 11), press **MENU** — **9** — **1** — enter base ID (00–07) — **2** to select Flash key timing.
  - b. Nine timing selections (100 ms–900 ms).
  - c. The default timing value (300 ms) works in most areas. Changing this setting may result in Flash function not working. Change only when you are certain the new value will work.
  
3. Call Transfer to PBX Extension (For DuraFon PRO only)
  - a. When the DuraFon PRO is installed behind a PBX system, you can pre-program the feature code of call transfer function.
  - b. Need to adjust the Flash time to match your PBX setting.  
If administrator handsets (handsets 10 and 11) are lost, all settings must be reset (reset the base and re-register all handsets).

# Charger Illustration

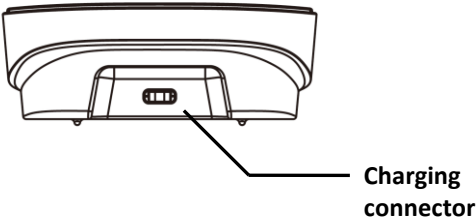
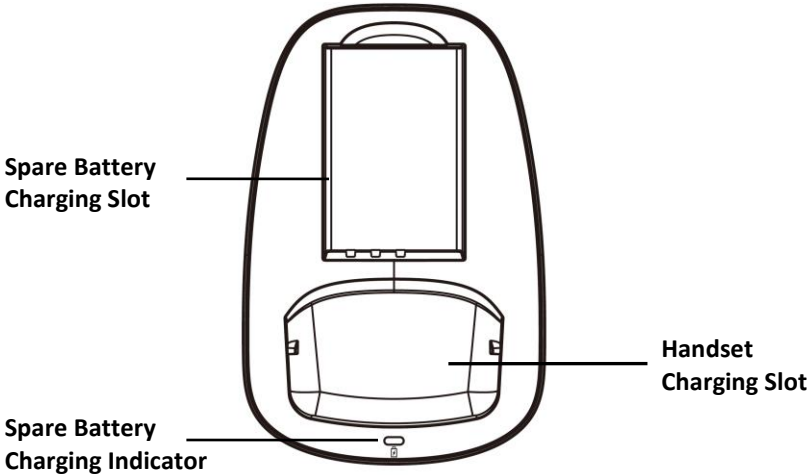

# Charger Features

1. DC In  
Connection for charger AC adaptor.
2. Handset Charging Slot
  - a. The handset battery will charge when the handset is placed in the cradle.
  - b. The handset LCD will indicate charging status:
    - Charging: The battery status bar is animated and the LCD screen displays a “Charging” message.
    - Fully Charged: battery status bar stands still and the LCD screen displays a “Fully Charged” message.
    - Charge Fail: If an error occurs while charging, the LCD screen will display a “Charge Fail” message.
3. Spare Battery Charging Slot
  - a. Place spare battery in slot to charge.
  - b. LED indicator:
    - Green: Charging
    - Off: Fully charged (or no battery in slot)
4. It is impossible to overcharge the battery using this charger.

**Notes:**

1. Fully charge battery packs before first use.
2. One handset and one spare battery can be charged at the same time.

# Getting Started

## Handset and Charger Installation

1. Plug the transformer end of the charger AC/DC adaptor into a standard AC electric power outlet. Plug the other end into the “DC In” jack on the back of the charger.
2. Install battery pack onto the handset.
3. Install handset antenna.
4. Place handset onto the front charger slot.
5. Fully charge the battery for three hours before use.
6. The phone system is now ready to perform basic functions such as making and receiving phone calls and intercom calls. No base station or handset programming is needed for basic operations.

### Notes:

1. Handset(s) packaged along with a base station are pre-registered at the factory. If you have a new handset, you will need to register the handset with the base station in order to be recognized as a member handset by the base(s) and by other handsets. See Handset Registration.
2. Fully charge battery packs before the first usage.

# Basic Operations

## Operation Modes

Both the base station and handset have levels of operation at which only certain procedures or functions can be performed.

### *Base Operation Modes*

1. **IDLE mode:** This is the default operating mode. Intercom, broadcast, and volume keys are active.
2. **TALK mode:** The base operates in this mode during phone call, intercom, and broadcast operation. The “In Use,” “Intercom,” and “Broadcast” LED indicators will light up respectively.
3. **REGISTRATION mode:** The base enters this mode when the REG button is held for three seconds. In this mode, no base unit keys are active. Four LEDs will be lit when the base is in Registration mode.

### *Handset Operation Modes*

1. **IDLE mode:** This is the default operating mode.
  - If there is no on-going activity, the handset automatically goes into SLEEP/IDLE mode to save battery power.
  - Turn the On/Off/Volume knob clockwise. You will hear a beep-beep tone and see LCD and backlight to indicate the handset is ON.  
To turn the handset off, the Power/Volume knob counterclockwise.
  - The idle screen display name can be edited.
  - The 2-digit number represents the handset ID.

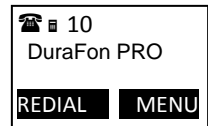

2. **MENU mode**
  - Press the right soft key to activate MENU mode.
  - In MENU mode, the handset settings and information contained in memory can be changed.
  - The functions available through the MENU selection are covered in greater detail beginning on page 38.
  - The MENU structure display is shown below:

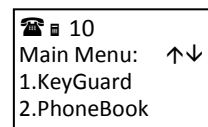

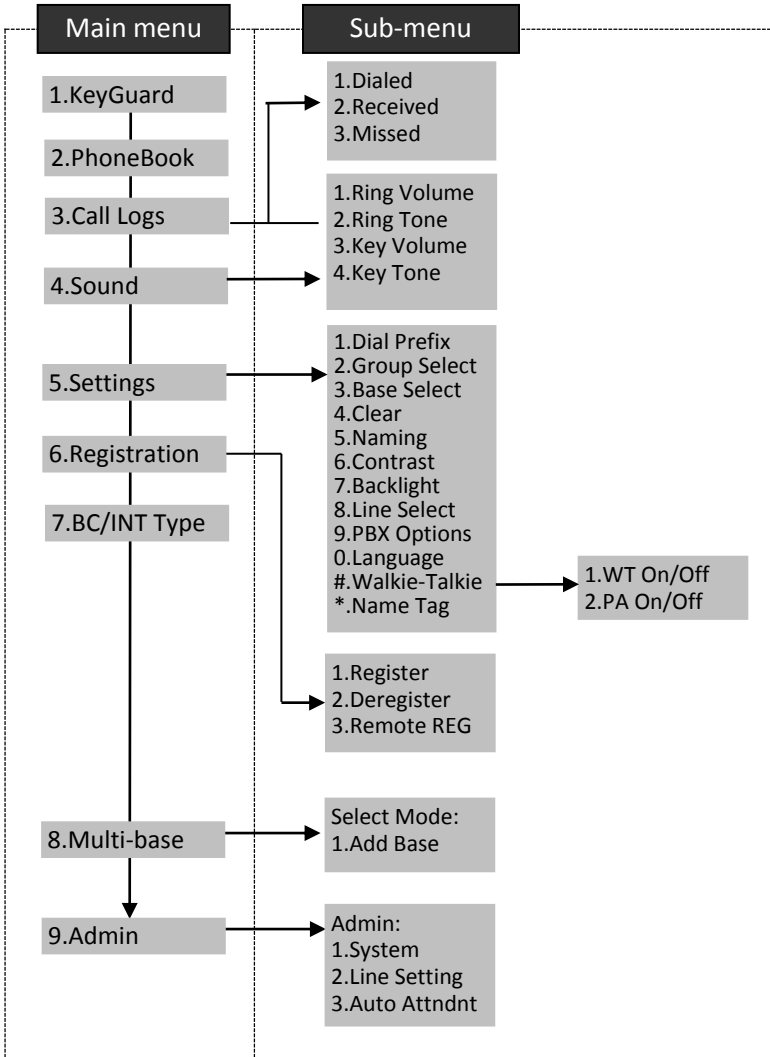

## Menu Tree (Register to PRO base only)







## Making a Telephone Call

Press , wait for dial tone, and then enter a phone number.

Alternatively, first enter a phone number then press .

When using this method, you can use the **CLEAR** (left soft key) and **DELETE** (right soft key) to edit the number entered. “Delete” erases the last digit entered. “Clear” erases the entire line, but the phone remains in idle mode.

### **Speed dial by accessing the phone book:**

1. Press the Up/Down key to enter the phone book.
2. Press  to dial the number.
3. To abort dialing, press .

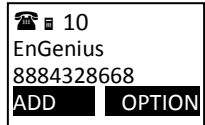

### **Notes:**

1. After a link is established, the Base ID will appear on the upper-right corner. If no Base ID appears, you are approaching the boundary of coverage.
2. If the line is occupied, the LCD shows “No Line Available” and the handset returns to idle mode.
3. If a link cannot be established, the LCD will show “No Base” after a 12-second time out.
4. A call duration timer will appear, displaying the length of the call, once a link is established.
5. During the call, press  to activate the speakerphone.

## Making an 2-Way/ Intercom Call

The EnGenius Industrial Cordless Phone System offers private Intercom/2-way radio calls independent of the base station. Intercom/2-way communication can be initiated from, and directed to, any base station or handset.

### **Handset to Handset Calls**

Press  followed by a two-digit handset ID or Group

1. ID to initiate a call.

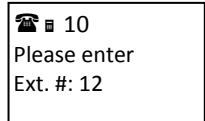

2. Press  to end the call.

**Notes:**

6. Intercom calls can be made regardless of whether the base station is present.
7. If a group ID is entered, the first handset (belonging to that group) that answers will establish a link with the caller. See “Handset Group Subscription.”
8. If a link cannot be established, the LCD shows “No Connection” after a 12-second timeout.
9. During the call, press  to activate the speakerphone.

## Making a Broadcast via 900MHz

### *Handset to Handset Calls*

Since the DuraFon-UHF-HC is able to broadcast to the DuraFon-PRO system handsets via 900MHz, or to other DuraFon-UHF-HC or other UHF radio handsets via UHF band, you must choose the desired frequency for walkie-talkie operation before initiating a broadcast.

To activate walkie-talkie mode: enter the key sequence **MENU**—**5**—**#**—**1**, then select “OFF” to enable WT mode in the digital 900MHz band.

Press “End” to return to idle mode. The walkie icon will disappear from the display.

Broadcasting to all handsets in range:

1. Press and hold the **PTT** (push-to-talk) key on one handset.
2. Listen for a 2-short-1-long beep sequence, which signifies that the initiating handset is broadcasting to all handsets within communication coverage.
3. Start to speak after the “beep” sound; the speakerphones on destination handsets will be activated.
4. Release the **PTT** key to end the broadcast.

Broadcasting to a group of handsets:

1. Enter the group ID and then press and hold the **PTT** (push-to-talk) key on one handset.
2. Listen for a 2-short-1-long beep sequence, which signifies that the initiating handset is broadcasting

 10  
PA paging  
to Ext. # 02

- to all handsets within communication coverage.
- 3. Start to speak after the “beep” sound; the speakerphones on destination handsets will be activated.
- 4. Release the **PTT** key to end the broadcast.

Broadcasting to an individual handset:

- 1. Enter the handset ID and then press and hold the **PTT** (push-to-talk) key on one handset.
- 2. Listen for a 2-short-1-long beep sequence, which signifies that the initiating handset is broadcasting to all handsets within communication coverage.
- 3. Start to speak after the “beep” sound; the speakerphones on destination handsets will be activated.
- 4. Release the **PTT** key to end the broadcast.

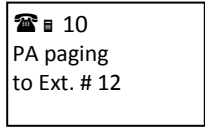

## Making a Broadcast via UHF

### Handset to UHF Walkie-Talkie Calls

Activating walkie-talkie mode:

- 1. Enter the key sequence **MENU—5—#—1**, then select “OFF” to enable WT mode in the digital 900MHz band.
- 2. Press “End” to return to idle mode. The walkie icon will disappear from the display.

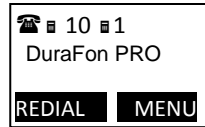

Broadcasting to all UHF walkie-talkie handsets in range:

- 1. Ensure that all handsets share the same setting for Channel/ Frequency/Code.
- 2. Press the **PTT** (push-to-talk) key. The LCD will display the selected channel. The handset is now ready to transmit to all handsets within communication coverage.
- 3. Start to speak immediately; the speakerphone of destination handsets will be activated.
- 4. Release the **PTT** key to end the broadcast.

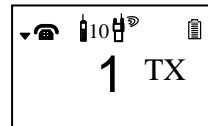

## Redial

- 1. Press **REDIAL** (left soft key).

2. The LCD display will show the last phone number dialed. To dial this number, press **DIAL** (left soft key).
3. Use the Up/Down key to scroll through the last 10 phone numbers dialed. Select a number and press **DIAL**.

**Note:**

Intercom numbers (handset IDs) are not stored in the last 10 numbers dialed log.

## Receiving a Telephone Call

When an incoming call arrives, the ringer will ring or vibrate unless the ringer has been turned off.

If the handset is on the charger cradle (ringer will be temporarily switched to “Ring” if it had previously been set to “Vibrate”), lift the handset and start conversation.

If the handset is not on the cradle, press any key (except  or the **SILENT** soft key) to answer.

**Notes:**

1. Press **SILENT** (left soft key) to ignore the call. Unlike turning off the ringer (from the handset menu), the **SILENT** key operation is valid only for the current call.
2. If caller ID service is available, the LCD will display the incoming call information. If the LCD shows “Private” or “Unknown,” the caller’s information may have been blocked by the caller or the originating phone company.
3. During the call, press  to activate the speakerphone.

## Receiving an Intercom Call

When an intercom call arrives, the ringer will ring or vibrate unless the ringer has been turned off. Press  to answer the intercom call.

If the handset is on the charger cradle (ringer will be temporarily switched to “Ring” if it has been set to “Vibrate”), lift the handset and start conversation.

If the handset is not on the cradle, press any key (except  or the **SILENT** soft key) to answer.

**Notes:**

1. The LCD displays the caller’s handset ID.
2. Press **SILENT** (left soft key) to ignore the call. Unlike turning off the ringer, the **SILENT** key operation is valid only for the current call.
3. During the call, press  to activate the speakerphone.

## Ending a Call

To end a telephone or intercom call, press  or place the handset into the charger cradle.

## Adjusting Receiver (Earpiece) Voice Volume

Voice volume can only be adjusted during a call.

There are 6 volume levels; the default setting is 3. Use the Up/Down key to adjust.

The new setting remains effective for all future calls until changed.

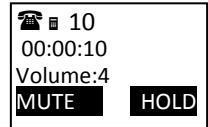

## Adjusting Speaker Volume

The speaker volume can only be adjusted with the Power/Volume knob.

Rotate the knob clockwise to increase and counterclockwise to decrease volume.

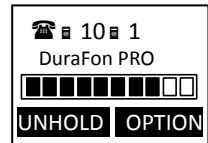

## Placing a Call Hold

When a call is in progress, it can be put on hold by pressing **HOLD** (right soft key).

To return to the conversation, press **UNHOLD**.



### Notes:

1. A call placed on hold can only be retrieved by the handset that puts it on hold.
2. The handset LCD indicates that a call is on hold. An alert tone (double beep) every 30 seconds reminds the handset user that a call is on hold.
3. If the operation (e.g., call transfer) after putting a call on-hold fails, the held call may be dropped.
4. You can power off the handset (e.g., to change the battery) while a call is on hold. When power is restored, press **UNHOLD** (left soft key) to terminate the hold state.

## Mute

After a link is established, you can press **OPTION** (left soft key) and then **0** to mute the handset microphone.

When mute is active, the caller on the other end will not hear your voice, but still can speak to you.

To leave the mute state, press **UNMUTE** (left soft key). Mute is effective only for the current call.

## Do Not Disturb (Silent Ring)

Enter the key sequence **MENU—4—1**, then select "Off."  
Press **SAVE** to confirm your choice. This will turn off the ringer until it is turned on again from the menu.

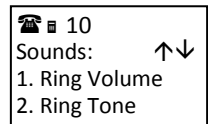

To temporarily silence the ringer when an incoming call arrives, press **SILENT** (left soft key).

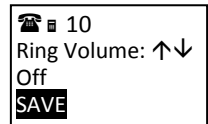

## KeyGuard

To prevent accidental dialing, you can press **MENU** (right soft key), then **1** to select KeyGuard. The handset keypad will be locked. No key entry will be accepted while KeyGuard is active except the Power on/off key.

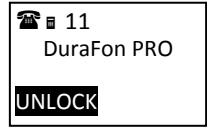

To unlock the keypad, press **UNLOCK** (left soft key), then, within 2 seconds, press the **1** to unlock.

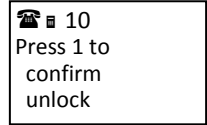

KeyGuard remains in effect until the handset is unlocked or powered off.

## To View Missed Call(s)

To view missed incoming call(s), press the **VIEW** soft key to enter the call logs.

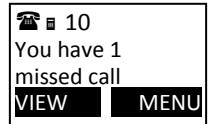

You must subscribe to caller ID service from a local telecom company to use this feature.

## To Call Back from Call Log

While reviewing missed incoming call(s), you can call back directly by pressing .

The displayed CID (customer identification number) in most cases will be a 10-digit number (3-digit area code followed by 7-digit telephone number). If the area code is unnecessary for calling back, you can follow this procedure to adjust the callback number:

1. Press **FORMAT** once to remove the 3-digit area code.
2. Press **FORMAT** twice to add "1" in front of the original displayed number.
3. Press **FORMAT** three times to return to the original displayed number.

(The CID default is 10 digits. When a user presses the **FORMAT** key, the number will rotate between its 7-digit, 11-digit, and 10-digit forms.)

After choosing a number, press  to call back.

## Battery Recharge and Replacement

Charge the battery when any of the following happen:

- Phone beeps twice every two seconds.
- Battery icon is empty.
- Phone does not respond when a key is pressed.
- LCD and backlighting become dim.
- Talk range shortfall is experienced.

You can replace the handset battery while a call-in-progress is on hold.

Battery talk time and standby time vary depending on the talk/standby pattern and the operating distance. Putting the handset back to charger cradle as often as possible is recommended for best performance. ***Use only the manufacturer-provided battery and charger!***



# Walkie-Talkie Mode

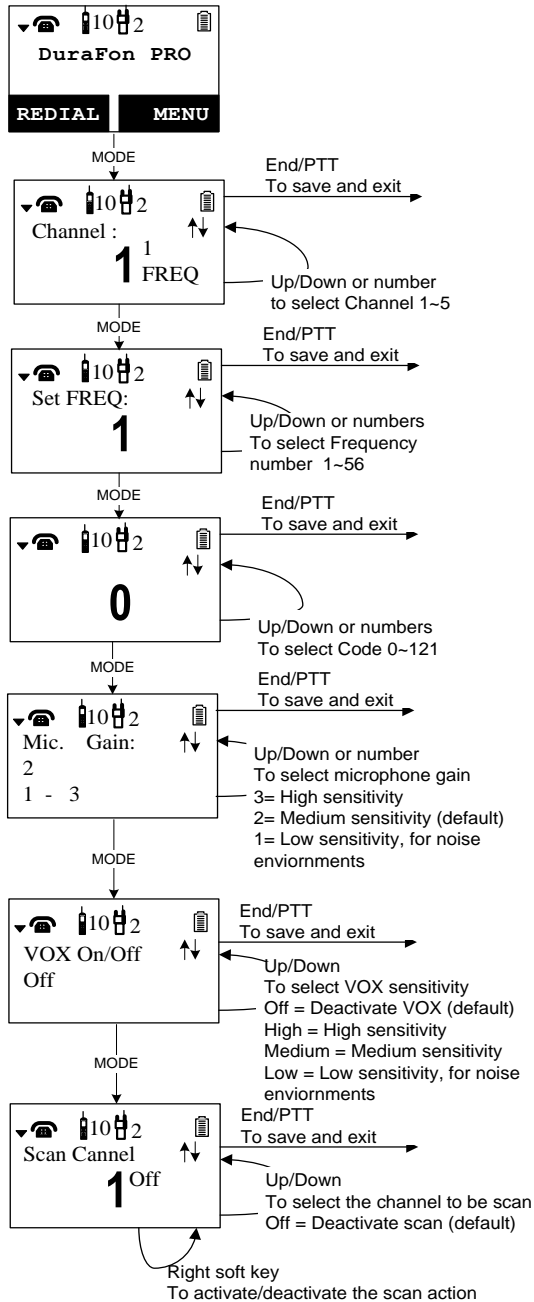

### **To program Walkie-Talkie mode:**

1. Press the “Mode” key.
2. Press the Up/Down key to scroll the channel selection. Channels 1 to 5 are used for UHF band, while channel 6 is used for digital band.
3. Press the “Mode” key to enter the desired frequency number setting. You can enter using number keys directly (1–56), or use the Up/Down key to scroll to the frequency number.
4. Press the “Mode” key to enter the desired Code number setting. You can enter using the number keys directly (0–121), or use the Up/Down key to scroll to the code number.
5. Press the “Mode” key to set the desired microphone gain setting. Use the Up/Down key to scroll to the gain level (1–3).  
3= High sensitivity  
2= Medium sensitivity (default)  
1= Low sensitivity, for noisy environments
6. Press the “Mode” key to select the VOX sensitivity (setting for headset only). Use the Up/Down key to scroll to the VOX activate gain level (1-3).  
3= High sensitivity  
2= Medium sensitivity  
1= Low sensitivity, for noisy environments  
Off= Deactivate VOX (default)
7. Press the “Mode” key to enter the scan channel setting. Use the Up/Down key to scroll to the desired channel. Use the left soft key to activate/deactivate the scan. If the LCD displays “Off” on the right side, scan is deactivated (default).
8. Press the “End” or **PTT** key to store and exit the two-way programming mode.

# Advanced Operations

## **Handset Registration (Register to PRO base only)**

Upon first use of a handset, you must register the handset to the base station. (The handset ID is 00 before registering to the base station.)

It is possible to change a handset’s ID. Such a change is useful for promoting a handset from a user to an administrator (ID 10 or 11) (or vice versa) or differentiating two handsets with the same handset ID.

### **Registration**

1. Press MENU—**6** to enter the registration mode

2. Press and hold the base's **REG** (Registration) button for 2 seconds until the L1, L2, L3, and L4 LEDs come on.
3. Press **1** on the handset to complete the registration process. The base station will assign a handset ID between 10 and 99. The assigned ID will be displayed on the handset LCD, indicating successful registration.
4. Repeat these steps for all additional handsets.

**Notes:**

1. The first two handsets registered will be given IDs 10 and 11, which gives them administrator privileges.
2. Base 00 is a primary base. All handsets must register to Base 00.

### ***De-registration***

You can de-register a handset from a base. De-registration will reset the handset ID to 00, erase the system security code, and free up the old ID for future registration.

After deregistration, the handset will not be able to use the base to make or receive phone calls, nor can it use the intercom to reach other handsets.

1. Press **MENU** (right soft key) on the handset.
2. Press **6** on the handset to enter the handset registration menu.
3. Press and hold the base's **REG** button for 2 seconds until L1, L2, L3, and L4 LED come on
4. Press **2** on the handset to complete the de-registration process. Upon successful de-registration, the handset will display ID "00."

**Notes:**

3. The base has a 30-second registration timeout (starting from depression of the **REG** button). The handset has a 12-second registration timeout (starting from the time registration or de-registration option has been selected). The base and handset will automatically exit registration mode after timeout.
4. Repeat registration or de-registration process if unsuccessful.

### **Advanced Registration (Register to PRO base only)**

Advanced registration functions can be performed with administrator handsets (ID 10 and 11) only.

Administrator handsets can be used for advanced registration functions as long as

they are within range of the base station. The base station does not need to be in registration mode.

***De-register a handset ID by administrator:***

1. Make sure that the administrator handset is within the coverage range of the base station.
2. Press administrator handset's **MENU** (right soft key)
3. Press **9** to enter the handset administration menu.
4. Press **1** to enter the system setting menu.
5. Press **2** and enter the two-digit handset ID to be cleared.
6. Upon successful de-registration, the handset LCD will display "Done." If unsuccessful, it will show "Message not received, try again".

***Obtain a specific handset ID:***

If a particular handset ID is preferred over sequentially assigned IDs, the administrator can "tell" the base what the next ID assignment should be.

1. Press the administrator handset's **MENU** (right soft key).
2. Press **9** to enter the handset administration menu.
3. Press **1** to enter the system setting menu.
4. Press **5** and enter the two-digit handset ID to be assigned next by the base.
5. If successful, the handset LCD will display "Done;" otherwise it will show "Message not received, try again."
6. If the handset ID is already in use by another handset, the administrator will be alerted. In that case, the administrator can choose another ID or ask the handset having the desired ID to vacate by de-registering with the base.
7. Perform registration of the appropriate handset immediately after programming the ID to ensure that the ID is not assigned to another handset.

***Remotely register a handset:***

1. If the base is installed in the ceiling or other unreachable location, administrator handsets can perform remote registration.
2. Press the administrator handset **MENU** (right soft key)
3. Press **6** to enter registration mode.
4. Press **3** until the L1, L2, L3 and L4 LED come on.
5. Proceed with the handset registration process for additional handsets.

**Notes:**

1. De-registration by the administrator will disable a handset's ability to use the base station to make or receive phone calls. This also frees up the ID for future registration.
2. Handsets de-registered by the administrator can still make intercom calls to

other handsets.

## Handset Group Subscription

Up to seven handset groups (01-07) can be defined and registered to the PRO base. Individual handsets can decide which group(s) they want to join.

For example, if group 1 is the Customer Service group, group 2 is the Sales group, and group 3 is the Marketing group. If handset 11 wants to receive incoming rings for all Sales and Marketing related calls, handset 11 will need to “subscribe” to group 2 and group 3.

### Group Selection:

1. Press **MENU**—5 to enter the handset Settings menu.
2. Press **2** to enter the Group Selection menu.
3. Press the **ADD** soft key and enter a two-digit group number (01-09) to add membership in a group.
4. Repeat for all desired groups.

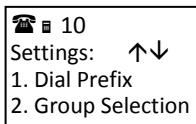

Delete group selections by pressing the **DELETE** soft key and entering the group number.

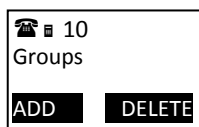

### Notes:

1. The handset can change group affiliations at any time.
2. The base (administrator) is not responsible for group assignments. Consequently, it cannot de-subscribe a handset from a group.

## Call Transfer (Register to PRO base only)

While a telephone call is in progress, you can place the call on hold and transfer the call to another handset.

Press the **HOLD** soft key to put the call on hold.

Press the **OPTION** soft key to enter the feature list.

Press **2** and enter a two-digit handset ID to call another handset extension.

### ***Un-announced Call Transfer:***

Press  before the destination handset answers. The call is automatically transferred to the destination handset.

### ***Announced Call Transfer:***

1. Speak to the destination handset.
2. Press the **XFER** soft key or  to end the announcement. The call is then transferred to the destination handset.

#### **Notes:**

1. If the destination handset does not answer after handset paging timeout, the call is routed back to the originating handset.
2. The above described call transfer" process is for DuraFon PRO handset-to handset call transfers.

## **3-Way Conferencing (Register to PRO base only)**

While a telephone call is in progress, you can place the call on hold and bring in another phone line or another handset for a 3-way conference.

1. Press **HOLD** (right soft key) to put the current call on hold.
2. Press **OPTION** (right soft key) to enter selection menu.
3. 3-Way Conferencing with a second handset:
  - a. Press **2** and enter a two-digit handset ID to call another handset extension.
  - b. After the second handset answers, press **CONF** (left soft key).
  - c. Two handsets and one phone line can now talk simultaneously. Any one party can drop out of the 3-way conferencing, leaving the remaining two parties still connected.
4. 3-Way Conferencing with a second phone line:
  - a. Press **1** and enter a phone number to call another phone line.
  - b. After the second line answers, press **CONF** (left soft key).
  - c. One handset and two phone lines can now talk simultaneously.
    - If one phone line hangs up, the handset continues talking to the remaining phone line.

- If the user presses , the 2nd phone line will be dropped. The handset and the first phone line continue conversation.

**Notes:**

1. 3-way conferencing between 3 handsets is not supported.
2. Unlike 3-way conferencing provided by the phone company, 3-way conferencing involving 2 phone lines will take up two physical lines, leaving only two lines left available for other handsets. The handset must have access to a second line.

**Base Select (Register to PRO base only )**

A handset can manually select the desired base station before accessing an outbound line.

1. Press **MENU** (right soft key).
2. Press **5** to enter the handset Setting menu.
3. Press **3** to enter Base Select mode.
4. Use the Up/Down key to scroll between on and off.
5. Make a selection (default = off), and press **SAVE** (left soft key).

**Notes:**

1. When Base Select is on, you must a enter 2-digit Base ID after pressing .
2. The handset must be in range of the base station to initiate this procedure.

**Call Waiting (Register to PRO base only)**



A handset on an active call can be informed of the arrival of a new incoming phone call.

For example: Handset 15 has an active call on Line 1. A new call comes in on Line 4. The call is sent to handset 15 (because the caller enters extension number “15” when prompted, or the call is set to be routed to handset 15 when AA is disabled).

The base station recognizes that handset 15 is busy. Instead of announcing to Line 4 that handset 15 is busy, the base sends an alert to handset 15.

Upon receiving the alert, the handset sounds an audible double-beep alert and the LCD displays “New call on Line 4.”

Handset 15 can:

- a. Ignore the new call; continue talking to Line 1.
- b. Press **Switch** to switch to Line 4.
- c. Subsequent pressing of  will toggle between Line 1 and Line 4.
- d. Pressing  while talking to either line will terminate that call and automatically connect to the remaining line.

**Notes:**

1. This built-in call waiting is separate from the call waiting feature available from the local phone company. The phone company provides call waiting switching on one phone line, while DuraFon's call waiting functions on two separate phone lines.
2. This feature only works for 2 lines. If a third phone call comes in for the same handset, the call will not be routed to the handset.
3. When establishing service with a local phone company, it is recommended to order the "hunt group" feature for all your lines rather than the call waiting feature.

## **Auto Attendant (AA) (Register to PRO base only)**

When enabled by the administrator, an automated attendant will greet an incoming telephone call.

The caller will be prompted by the greeting message to enter a two-digit extension number (handset ID) or press 0 for operator.

The greeting message is user-programmable. The handset ID that is designated as the operator is also user programmable.

- Default greeting/main outgoing message (OGM): "Please enter the extension number or press 0 for the operator."
- Default operator: handset 10.

If the caller enters an invalid ID (no registered handset with that ID), the AA will ask for another handset ID with the announcement (OGM2): "The extension you entered is invalid, please try another extension or press 0 for the operator".

If there is no entry timeout, the AA will announce (OGM3): "Please hold; your call is being transferred to the operator," and automatically ring the



operator handset.

If the destination handset does not answer (busy, power off, or out of range) after handset paging timeout, the AA prompts the caller for another extension number by announcing (OGM5): “The extension you’ve entered is busy or not available. Please enter another extension number or press 0 for the operator”

If the 2nd try is still not successful, the AA will announce (OGM4): “Sorry, nobody can answer your call right now. Please try again later, goodbye,” then disconnect the call.

When the DURAFON PRO base station is connected to wired PBX extension lines, calls addressed/routed to the AA operator can be sent back to the operator of the wired PBX system. From an administrator handset, a user can program up to 10 keys/digits to transfer the calls back to the wired PBX. This feature can only be enabled and pre-programmed by an administrator handset (handset ID 10 or 11). Consult with the wired PBX manual for operation instructions and the correct key sequence for transfer calls to the operator from an extension.

**Notes:**

1. Intercom calls are not routed by the Auto Attendant.
2. Routing messages OGM 2,3,4 and 5 are not user programmable.
3. The timeout for entering an extension number is 5 seconds.
4. Calls can be routed to either a handset ID or an extension number of the wired PBX system. There can be only one operator for the AA, which is either a DURAFON PRO handset or the wired PBX operator.
5. Call routing is limited at two transfers. That is, if both the 1st and the 2<sup>nd</sup> handsets do not answer, and the operator does not answer, the call will be terminated.

**AA Configuration by Administrator (Register to PRO base only)**

An administrator can change the following AA settings:

- Record/playback a new main greeting message.
- Set the number of rings before AA picks up a call.
- Turn on/off the AA line-by-line.
- Set the designated handset ID for AA disabled line(s). When AA is disabled for a particular line, that line can be dedicated to either an individual handset ID (10-99) or a group ID (01-07), which can then use that line for incoming and outgoing calls.

- Designate a handset to serve as operator. This handset will answer un-routable calls or calls during which the caller chooses “Operator.”

## Change AA Parameters (Register to PRO base only)

1. From an administrator handset (handset 10 or 11), press **MENU** (right soft key).
2. Press **9** to enter the administration menu.
3. Press **3** to enter the AA setting menu.
4. Press **1** and follow instructions to record a new greeting message.
5. Press **2** to play back the current greeting message.
6. Press **3** to set the number of rings allowed before the AA picks up a call. Use the Up/Down key to choose between 2 and 9 rings.
7. Press **4** to turn AA On/Off. This can be done separately for each phone line by using the Up/Down key to scroll through Line 1 to Line 4, and press **On** or **Off** soft key to turn AA On/Off. If turning off the AA may be useful when the line is not used by a group of people, or when an external answering machine is to be attached to the line.
8. Press **5** and select from the following two options to set an operator handset for the AA:
  - a. Handset: assign a specific handset as operator by entering a two-digit handset ID (default=Handset 10) as operator for all calls addressed to the operator when AA is on.
  - b. PBX: transfer calls to be answered by the operator back to the designated wired PBX operator. System administrators must know the proper programming and call transfer feature code (available from the user manual of the wired PBX system) in order to perform this function correctly.

Example: route a call back to the PBX system by pressing “-**7**-**0**-**1**-**8**-**3**-**0**.” (Press the Flash, then the call transfer code “70,” immediately followed by the extension number “1830.” Confirm the set up using the **SAVE** (left soft key).

### Notes:

1. Only an administrator can change AA settings.
2. Because AA settings are stored on the base station, the handset must be in range of the base to make changes.
3. The maximum recording time for the greeting message is 128 seconds.
4. Allowing each line’s AA to be turned on or off separately is useful if different lines are used for different purposes.
5. When AA is disabled, the line can be dedicated to either an individual handset

ID or a group ID.

6. The operator can be any individual handset or a group; it doesn't need to be an administrator handset (handsets 10 and 11).
7. The minimum number of rings before the AA picks up cannot be lower than two for the purpose of receiving the Caller ID message.

## Line Dedication (Register to PRO base only)

Line dedication function can be performed by administrator handsets (IDs 10 and 11) only.

(By default all incoming calls will ring all handsets.)

Press **MENU**—**9**—**2**—**2** for the Line Dedication setting.

The LCD will first show line 1 and line status. If you wish to dedicate line 1 to a specific handset or group, you need to press **OK**. To select lines 2–4 use the Up/Down key.

After choosing a line, the display will read **YES** and **NO**. Select **YES**, to enter the appropriate handset ID or group ID. If you choose **NO**, it will go back to Line Setting menu.

### Notes:



1. When entering the line dedication setting, the LCD will show the current selected line and status. If the line is already dedicated to a specific handset or group, the display will indicate the handset or group ID. If the line isn't dedicated to a specific handset yet, the display will read "ALL HS."
2. When setting up line dedication, make sure the handset or group ID is correct to avoid losing calls sent to a DuraWalkie handset or invalid ID.
3. Handsets dedicated to a port will receive calls from non-dedicated lines as well as the handset's dedicated line. Use line dedication for separate groups on other lines to further manage calls.

## Line Selection (Register to PRO base only)

Press **MENU**—**5**—**8** while the phone is in standby to enter the Line Select menu.

Use the Up/Down key to switch between **On** and **Off** settings; the default is Off.

If Line Selection is set to On, the handset LCD display will prompt a user placing a

call (with ) or by entering a phone number and pressing ) to “Select Line” and will show available options (1–4). Select from one of the available lines (i.e. press **1** to select line 1 and press **2** to select line 2).

This feature is also supported when selecting a second line during call conferencing.

## Change System and Line Settings by Administrator (Register to PRO base only)

Several system parameters can be changed by the administrator..

From an administrator handset (10 or 11):

1. Press **MENU** (right soft key).
2. Press **9** to enter the administration menu.
3. Press **1** to enter the system setting menu.
  - a. Dial Tone:  
Press **1** to set up the dial tone to be either “Tone” or “Pulse.” Press **1** to choose “Tone” or press **2** to choose “Pulse.”
  - b. Flash Time:  
Press **2** to set up the flash time from 100ms, 200ms, to 900 ms (9 levels to choose from.) For example, press **2** if the desired flash time is 200ms.
  - c. Line Detect:  
Press **3** to set up the line detect to be either “On” or “Off.” Press **1** to choose “On” or press **2** to choose “Off.”
  - d. Clear Handset ID:  
Press **4** and enter a two-digit handset ID when prompted to clear this ID for later assignment.
  - e. Set Next Handset ID:  
Press **5** and enter a two-digit handset ID when prompted. This is the ID that will be given out by the base to the next handset registering with the base.
4. Press **2** to enter the Line Setting menu.
  - a. Enter the Base ID (00–07) to access base.
  - b. Press **1** to enter the broadcast setting menu.
    - Press **OFF** (right soft key) to disable broadcasting function
    - Press **ON** (left soft key) to enable broadcasting function.
  - c. Press **2** to enter Line Dedication setting.
    - Select the base’s line and press **CHANGE** (right soft key)
    - Line Dedicate confirm:  
Press **NO** (right soft key) to go back to the Line Setting Menu.  
Press **YES** (left soft key) then enter the extension number.

**Note:**

De-registration by the administrator will disable a handset's ability to use the base station to make or receive phone calls. This also frees up the ID for future registration.

## Phonebook Operations (Register to PRO base only)



1. You can store up to 90 entries in the phonebook. Each entry can contain a phone number or handset ID (up to 28 digits) and a name (up to 14 characters). (On a DuraWalkie, each entry can store 2 digits; a handset ID or a group ID.)
2. To access the phonebook, press **MENU** followed by **2** or scroll with the Up/Down key when the handset is in standby mode.
3. To add a new entry:
  - a. Press the **ADD** soft key.
  - b. Enter a phone number when LCD prompts "Number?" Use the **DELETE** soft key to delete the last digit entered. Press **SAVE** when the number is complete.
  - c. A prompt will appear requesting a name corresponding to the phone number.
    - (1) Press **SAVE** to save the phone number without a name. All records without a name will be placed on top of the list, in the order in which they are entered.
    - (2) To enter the name, press the corresponding keypad number one or more times according to the order of the character on the key.
    - (3) Use **DELETE** to delete the last character entered. When completed, press **SAVE** to confirm your selection.

**Notes:**

1. When entering a phone number, the cursor automatically advances to the next digit field. Use the Up/Down key to move the cursor backward or forward to insert or delete.
2. When entering a name, the cursor automatically advances to the next character field if you press a different key for the next character. If you need to enter consecutive characters from the same key, you can wait for the cursor to advance or use the Up/Down key to move the cursor backward or forward manually. Also use the Up/Down key to move the cursor to insert or delete.

3. By default, all letters are entered in the upper case. Use **\*** to toggle between upper and lower cases.
4. A "Pause" entry represents a 2.8 second delay in dialing the following digits, which is useful when calling a sequence of segmented numbers (e.g., access code, credit card number, auto-attendant entries, etc.) Pause is entered by pressing **\*** twice (the LCD displays P). Entering pause twice (PP) will result in 5.6 seconds pause in the dialing.

4. Entries are alphabetically sorted and stored as a list in ascending order (A to Z) from the top of the list.
  - a. If the phonebook is entered from the menu, the first entry displayed is from the top of the list.
  - b. If the phonebook is entered by pressing "Down," the first entry displayed is from the top of the list.
  - c. If the phonebook is entered by pressing "Up," the first entry displayed is from the bottom of the list.
5. The first line of the LCD display shows the name and the second line shows the phone number. If the phone number is longer than 14 digits, press **OPTION** and select Option 3 to view the complete number.
6. To search for a record:
  - a. Use the Up/Down key to enter Phone Book mode.
  - b. Press a key that corresponds to the first character of the name you are looking for.
  - c. For example, to search for "EnGenius," press **3** once.
  - d. Use the Up/Down key to locate the exact record you are looking for.
7. To erase a phonebook entry:
  - a. Use the Up/Down key or the alphabetical search method to locate the record to be erased.
  - b. Press **OPTION** to enter the editing menu.
  - c. Press **1** to erase the designated phone entry.
  - d. The LCD will ask, "Are you sure?" Press **YES** to confirm your change.
8. To edit a phonebook entry:
  - a. Use the Up/Down key or the alphabetical search method to locate the record to be edited.
  - b. Press **OPTION** to enter the editing menu.
  - c. Press **2** to edit the designated phone entry.
9. Dial from display:

- a. Press  or  to dial the phone number or handset ID displayed.
10. To transfer a phonebook:  
To transfer a phonebook, both parties first have to enter phonebook transfer mode:
- a. Press **OPTION—4** or use the Up/Down key when the handset is in phonebook mode.
- b. Sending the phonebook: press **1** to enter sending mode.
- (1) Either press **TX ALL** (left soft key) to transfer all phonebook entries to another handset(s), or press **TX ONE** (right soft key) to transfer one entry to another handset(s).
  - (2) Press the 2-digit handset ID or group ID of the recipient(s), then select phonebook entry or entries to be transferred.  
Re : “00” means all handsets
  - (3) During phonebook transfer, the LCD will display “Sending” a and 2-digit countdown indicating the number of phonebook entries waiting to be sent.
- c. Receiving the phonebook: press **2** to enter receiving mode.
- (1) When the handset enters receiving mode, the LCD will show “Ready”.
  - (2) When the handset is ready to receive the phonebook, the LCD will display “Get phonebook from Ext. # : xx.”
  - (3) As each entry is received, the handset will beep.
  - (4) A 2-digit countdown on the LCD will indicate the number of phonebook entries waiting to transmit.

Interference on a wireless network may cause errors in phonebook transmission. If this occurs, the LCD will display the message:  
**“Error! Bookmark not defined.”**

**Notes:**

## Character Table:

Key	Characters and Orders
1	' + , . * ( ) & 1
2	A B C 2
3	D E F 3
4	G H I 4
5	J K L 5
7	P Q R S 7
8	T U V 8
9	W X Y Z 9
0	0
*	Toggle case when in character editing * P (Pause) when in number editing
#	Space – when in character editing # when in number editing



## Programmable PBX Options (Register to PRO base only)

When the DuraFon PRO base unit is installed behind a PBX system, it is feasible to pre-program some PBX features along with their feature codes into the system.

Up to nine frequently used PBX feature codes can be pre-programmed.

To name and enter PBX feature codes:

1. Press **MENU** (right soft key) while the handset is in standby.
2. Press **5** followed by **9** to enter the “PBX Options” menu.
3. Press **ADD** to edit a PBX feature to be programmed.
4. Key in the name of the PBX features (see procedures for editing a phonebook entry; e.g., PBX Transfer. Press **SAVE** to confirm your entries.
5. Key in the feature code of the corresponding PBX feature; e.g., “Flash\*70”. Press **SAVE** to confirm the entry.
6. The first PBX feature and the corresponding feature code you enter will appear on the LCD screen. (In the LCD display, “F” represents the Flash signal.)
7. Press **OPTION** to Erase or Edit the PBX feature you program into the system.
8. Repeat the same operation to edit the second and even the third PBX feature that you will use frequently.

To use pre-programmed PBX features during a call:

1. Press **OPTION** while the handset is in talk mode .
- 2.. Press the number of the function you want to perform; e.g., press **1** to perform “PBX Transfer” function.
3. Press  to return to standby mode.

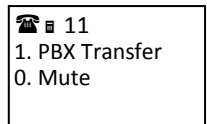
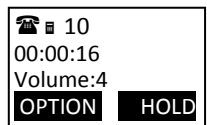
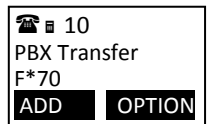
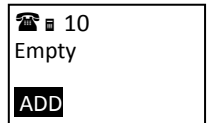
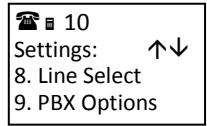

**Notes:**

1. This feature will be especially useful if the DuraFon PRO base unit is connected to a PBX system.
2. Only the “Mute” function will be displayed if you have not preprogrammed any PBX features into the system.
3. The DuraFon PRO’s programmable PBX options may not function with all PBX/Key systems due to the diversity of various proprietary systems.

## Broadcast through PBX (Register to PRO base only)

DuraFon PRO and DuraWalkie both have the broadcast function, enabling them to broadcast to another handset without going through the base station as long as the handsets are registered to the same system. However, when setting up a multi-base system, the broadcast feature may not be available due to the coverage range. In that case, you can use “Broadcast through PBX” to broadcast.

From an administrator handset (handset 10 or 11):

1. Press **MENU** (right soft key).
2. Press **9** to enter the administration menu.
3. Press **2** to enter the Line Setting menu.
  - a. Enter Base ID (00–07) to access base.
  - b. Press **1** to enter Broadcast settings.
    - (1) Press the Up/Down key to select L3 or L4 (The current status will be displayed on the LCD.)
    - (2) Press CHANGE to enter the setting mode; the base ID will be displayed on the LCD.
    - (3) Press On (left soft key) to enable the broadcast function. Press Off (right soft key) to disable the broadcast function.
    - (4) After enabling broadcast, press On (left soft key) to enable the AA. Press Off (right soft key) to disable the AA.

(L3 and L4 can each be set as broadcast lines. Repeat the steps above to enable the second broadcast line.)

When calling through line 3 or 4, the caller will be prompted by the greeting message to enter a two-digit extension number (01 –07 for group ID; 10–99 for handset ID; 00 for all).

- The greeting message is “Please enter the extension

- number.”
- If there is no entry after 5 seconds, the broadcast will be pushed to all handsets.

**Notes:**

1. Lines 3 and/or 4 can be reserved for the broadcast function.
2. For a single broadcast port, reserve line 3 for broadcast and dedicate (see pg. 46) line 4 to a non-existent handset (e.g., 99).
3. With a base unit configured with a single broadcast port, lines 1 and 2 may be used as standard telephone ports or lines.
4. For dual broadcast ports, reserve lines 3 and 4 for broadcast and dedicate lines 1 and 2 to a non-existent handset (e.g., 99).
5. Broadcast is limited to 30 seconds.

# UHF Frequencies and Codes

1 These frequency display numbers are equivalent to Motorola CLS/CPL frequency positions. **Each bandwidth uses 12.5KHz.**

Display Number	Frequency (MHz)
1	464.5000
2	464.5500
3	467.7625
4	467.8125
5	467.8500
6	467.8750
7	467.9000
8	467.9250
9	461.0375
10	461.0625
11	461.0875
12	461.1125
13	461.1375
14	461.1625
15	461.1875
16	461.2125
17	461.2375
18	461.2625
19	461.2875

Display Number	Frequency (MHz)
20	461.3125
21	461.3375
22	461.3625
23	462.7625
24	462.7875
25	462.8125
26	462.8375
27	462.8625
28	462.8875
29	462.9125
30	464.4875
31	463.5125
32	464.5375
33	464.5625
34	466.0375
35	466.0625
36	466.0875
37	466.1125
38	466.1375

Display Number	Frequency (MHz)
39	466.1625
40	466.1875
41	466.2125
42	466.2375
43	466.2625
44	466.2875
45	466.3125
46	466.3375
47	466.3625
48	467.7875
49	467.8375
50	467.8625
51	467.8625
52	467.9125
53	469.4875
54	469.5125
55	469.5375
56	469.5625

2 These interference eliminator codes display numbers are equivalent to Motorola CLS/CPL. display numbers. "0" disables interference elimiator codes.

Display Number	Code (Hz)
1	67.0
2	71.9
3	74.4
4	77.0
5	79.7
6	82.5
7	85.4
8	88.5
9	91.5
10	94.8

Display Number	Code (Hz)
11	97.4
12	100.0
13	103.5
14	107.2
15	110.9
16	114.8
17	118.8
18	123.0
19	127.3
20	131.8

Display Number	Code (Hz)
21	136.5
22	141.3
23	146.2
24	151.4
25	156.7
26	162.2
27	167.9
28	173.8
29	179.9
30	186.2

Display Number	Code (Hz)
31	192.8
32	203.5
33	210.7
34	218.1

Display Number	Code (Hz)
35	225.7
36	233.6
37	241.8
38	250.3

Display Number	Digital Code
39	023
40	025
41	026
42	031
43	032
44	043
45	047
46	051
47	054
48	065
49	071
50	072
51	073
52	074
53	114
54	115
55	116
56	125
57	131
58	132
59	134
60	143
61	152
62	155
63	156
64	162
65	165
66	172

Display Number	Digital Code
67	174
68	205
69	223
70	226
71	243
72	244
73	245
74	251
75	261
76	263
77	265
78	271
79	306
80	311
81	315
82	331
83	343
84	346
85	351
86	364
87	365
88	271
89	411
90	412
91	413
92	423
93	431
94	432

Display Number	Digital Code
95	445
96	464
97	465
98	466
99	503
100	506
101	516
102	532
103	546
104	565
105	606
106	612
107	624
108	627
109	631
110	632
111	654
112	662
113	664
114	703
115	712
116	723
117	731
118	732
119	734
120	743
121	754

# Menu Operations (Register to PRO base only)

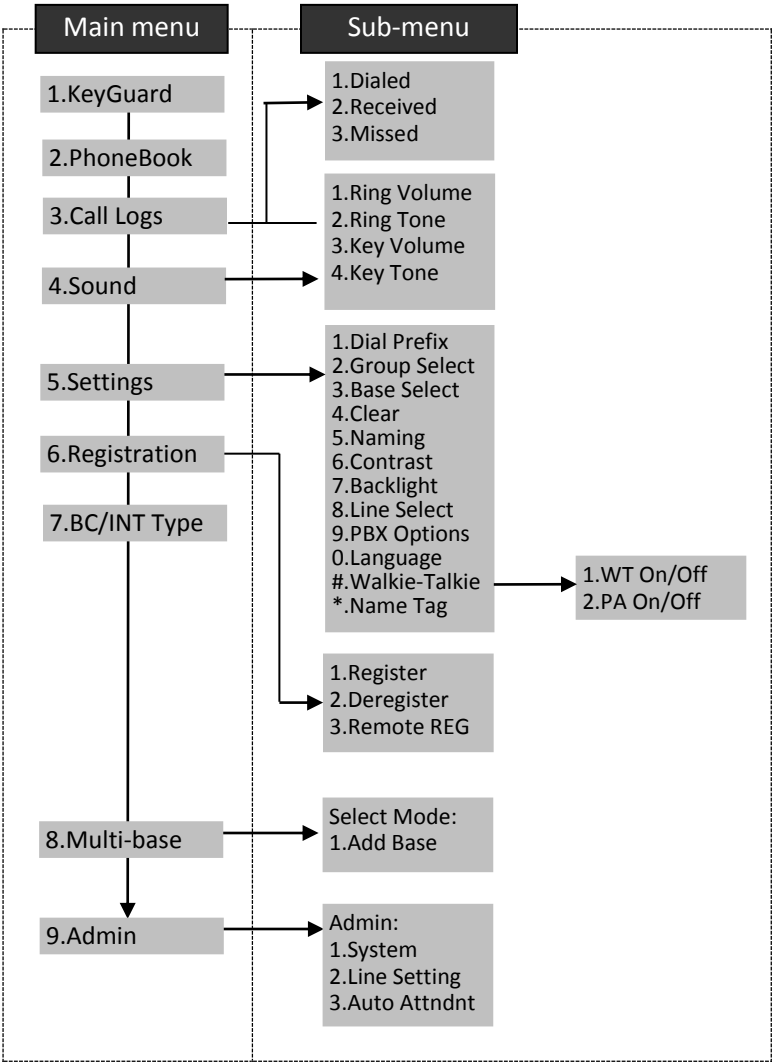

1. Press **MENU** (right soft key) while the phone is in standby.
2. Press **1** to lock keypad (see KeyGuard).
3. Press **2** to view, search, erase, edit and transfer the phonebook (see Phonebook).
4. Press **3** to view the last 10 numbers called, received, or missed. Records can be erased or edit/saved to the phonebook.
  - a. Press **1** to view the last 10 phone numbers dialed, starting from the most recent. Use the Up/Down key to scroll through the list. Press **OPTION** (right soft key) for options:
    - Press **1** and confirm to erase the current record.
    - Press **2** to edit and save or save without editing into the phonebook.
    - Press **3** to view the complete number if the phone number is longer than 14 digits.
  - b. Press **2** to view the last 10 phone numbers received, starting from the most recent. Use the Up/Down key to scroll through the list. Press **OPTION** (right soft key) for options:
    - Press **1** and confirm to erase current record.
    - Press **2** to view the arrival date and time of the call.
    - Press **3** to edit and save or save without editing into the phonebook.
  - c. Press **3** to view the last 10 phone numbers received but not answered, starting from the most recent. Use the Up/Down key to scroll through the list. Press **OPTION** (right soft key) for options:
    - Press **1** and confirm to erase current record.
    - Press **2** to view the arrival date and time of the call.
    - Press **3** to edit and save or save without editing into the phonebook.

The two-digit index on the upper right corner of the LCD display shows the call log location in ascending order, with 01 being the most recent call.

While viewing any of the three call logs, press **DIAL** (left soft key) to dial the phone number.

**Notes:**

1. Only phone numbers are stored in the three call logs. Intercom calls are not recorded.

2. Caller ID service is required from your local phone company in order to receive phone numbers, names and time stamps on incoming calls. The Received and Missed Call Logs will register no incoming calls if caller ID service is not available.
3. The caller ID feature may not be supported by all PBX or Key systems' analog ports, check with your equipment provider

5. Press **4** to set sound-related settings:
  - a. Press **1** to select ringer volume: Use the Up/Down key to scroll through six options: Low, Medium, High, Vibrate, Vibrate and Ring, Off. Press **SAVE** (left soft key) to save selection. The default setting is High.
  - b. Press **2** to select ringer tone: Use the Up/Down key to scroll through four options: 0, 1, 2, and 3. Press **SAVE** (left soft key) to save selection. The default setting is 0.
  - c. Press **3** to select the key volume when a key is pressed: Use the Up/Down key to scroll through 3 options: High, Low, and Off. Press **SAVE** (left soft key) to save selection. The default setting is Low.
  - d. Press **4** to select the key tone: Use the Up/Down key to scroll through four options: 0, 1, 2, and 3. Press **SAVE** (left soft key) to save selection. The default setting is 0.
6. Press **5** to change handset settings:
  - a. Press **1** to set the dialing prefix:
    - Use the Up/Down key to scroll and select on or off for the dialing prefix feature. The default setting is Off.
    - If "On" is selected, the handset is prompted to enter a prefix, up to 14 digits.
    - To enter a prefix, use **DELETE** (right soft key) and the Up/Down key to edit.
    - When the dialing prefix feature is turned on, for each outgoing phone call (except during redial or dialing by pressing ) the LCD will ask the user whether to use the dialing prefix. The current prefix will be displayed. Press **YES** (left soft key) add the prefix to the beginning of the number or **NO** (right soft key) to leave it out..
    - This feature is especially useful for access code, calling card, and credit card calls.
  - b. Press **2** to select a group. See Handset group Subscription.
  - c. Press **3** to turn Base Select on or off. The default setting is Off. See Base Select.
  - d. Press **4** to clear the call logs and phonebook:
    - Press **1** and confirm to delete the entire phonebook.



- Press **2** and confirm to clear the three call logs (Called, Received, and Missed).
- e. Press **5** to edit the name of a customer or line:
- e-1. Press **1** to change the power-up LCD display. (Show, for example, the customer name or other greeting message.
  - e-2. Press **2** to change the name of a line. When a call comes in, the LCD will indicate the originating line.
    - Use the Up/Down key to move the cursor backward or forward to insert (the character to the left of the cursor) or delete (the character above the cursor, or to the left of the cursor if the cursor is to the right of the last character).
    - Enter characters using the character table and method discussed in the Phonebook section of this manual.
    - Press **SAVE** (left soft key) to save the change.
- f. Press **6** to change the LCD display contrast:
- Use the Up/Down key to scroll through values **1 to 8**. Choose one that is most suitable to you. The default setting is **6**.
  - Press **SAVE** (left soft key) to save the setting.
- g. Press **7** to change the LCD backlight setting:
- Use the Up/Down key to scroll through three options: On, Off, and 20 Seconds. The default setting is 20 seconds (the backlight will automatically turn off after 20 seconds of inactivity).
  - Press **SAVE** (left soft key) to save the setting.
- h. Press **8** to change the line selection setting:
- Use the Up/Down key to toggle between On and Off. The default setting is Off. When line selection is off, the call will default to the first available line.
  - Press **SAVE** (left soft key) to save setting.
- i. Press **9** to change the PBX options:
- Press **ADD** to edit a PBX feature. Key in the name of the PBX features just like editing a phonebook entry.
  - Press **SAVE** (left soft key) to save the setting.
  - Press **OPTION** and **1** followed by entering PBX options mode to erase the PBX option.
  - Press **OPTION** and **2** followed by entering PBX options mode to edit the PBX option.
  - Press **OPTION** and **3** followed by entering PBX options mode to transfer the PBX options to other handset(s).

To transfer PBX Options, both parties have to enter the PBX Option mode:

Sender:

- (1) Press **1** to enter sending mode.
- (2) Either press **TX ALL** (left soft key) to transfer all PBX options to another handset(s), or press **TX ONE** (right soft key) to transfer a specific entry to another handset(s).
- (3) Press 2-digit handset ID or group ID, then select all PBX options or a specific entry to be transferred (“00” means all handsets)

While the PBX options are transmitting, LCD shows “Sending”, a 2-digit countdown on the LCD indicates the number of PBX options in the queue.

Recipient:

- (1) Press **2** to enter receiving mode.
- (2) Once the handset is in receiving mode, the LCD shows “Ready”.
- (3) When you start to receive PBX options, the LCD shows “Get PBX options from Ext. # : x mmm x.”

While the PBX options are transmitting, a 2-digit countdown on the LCD indicates the number of PBX options in the queue.

Notes:

1. Different PBX makers use different analog codes to control PBX function, like call transfer, call park, etc.; Please refer to your PBX maker’s manual for this information.
2. Errors may occur in PBX options and phonebook entries transferred wirelessly due to interference. Please re-enter manually if problems occur with an entry.

j. Press **0** to change Language:

- Use the Up/Down key to scroll through options: English and Portuguese. Default = Portuguese, meaning the LCD display shows in English.
- Press **SAVE** (left soft key) to save setting.

k. Press **#** to set Walkie-Talkie operation:

- (1) Press **1** to enable/disable **PTT** key for UHF WT (walkie-talkie)
- (2) Press **On** (left soft key) to turn on the UHF WT function which could receive and transmit the broadcast via UHF band. Press **Off** (left soft key) to turn off the UHF WT function. The **PTT** key is used for digital band.

- (3) Press **2** to turn Broadcast On/Off:
- Press **On** (left soft key) to turn on the broadcast function (including the broadcast of handset to handset and base to handset).
  - Press **Off** (left soft key) to turn off the broadcast function. When Broadcast setting is “Off”, there is an icon indicated in the display, side of the battery icon.
- (4) Press **\*** to turn Name Tag On/Off:
- Press **On** (left soft key) to turn on the name tag function, when receiving the incoming calls, the LCD will show the name which stored in phonebook.
  - Press **Off** (left soft key) to turn off the name tag function.
7. Press **6** to register or de-register a handset: See Handset Registration.
8. Press **7** to set up the intercom or broadcast via repeater (see Repeater Setup).
9. Press **8** to add new bases. From an administrator handset (Handset 10 or 11) you can add new bases 01–07. Maximum number of bases is eight (including master base 00). Before adding a new base, the handset must be registered to the master base (Base ID =00).
- a. Press **REG** button on new base.
  - b. Use Handset 10 or 11 to Add base: Press **MENU—8—1**.
  - c. Enter 01–07 (base ID).
10. Press **9** to change system and Line setting: See System and Line Setting.

# Technical Specifications

General Specifications	Phone Mode	Walkie-Talkie Mode
Frequency Range	902–928 MHz	461–469.5 MHz
Channel Number/Capacity	50	5 for UHF; 1 for 900 MHz
Channel Spacing	400 kHz	12.5 kHz
Number of System ID	65,535	NA
PL Codes	NA	38
DPL Codes	NA	83
Multiple Access	Frequency Hopping TDMA	FDMA
Duplex	Time Division Duplex (TDD)	Half Duplex
Frequency Hopping Rate	100 per second	NA
TDD Frame Length	10 ms	NA
Number of Slots/Frame	8	NA
Channel Coding	½ rate Convolutional + CRC	NA
User Data Rate	128 kbps Duplex	NA
Antenna Gain	0 dBi	2 dBi
Antenna Connector	Reverse SMA	
Average Battery Life	90 hours (Walkie Off)	27 hours (5/5/90)
Power Source	3.7V/2300 mAh Li-Ion Battery	
Charge Current	850 mA	
Charge Time	4 hours	
Regulation Compliance	FCC Part 15 FCC Part 68 RSS-210 CS03	FCC Part 90
Operating Temperature	-10–+60 °C	
Charging Temperature	0–+40 °C	
Storage Temperature	-40–+70 °C	
Humidity	0 % –95 %	
IP Rating	IP55	
Dimensions without Antenna (H x W x D)	142 x 60 x 38mm	
Weight	256.5 g	

Notes:

1. NA = Not Applicable.
2. The manufacturer reserves the right to change designs and specifications without notice.

# Index

- 2
  - 2-WAY INTERCOM, 15
- 3
  - 3-Way Conferencing, 38
- A
  - Adjusting Receiver (Earpiece) Voice Volume, 29
  - Administrator Features, 18
- B
  - Battery, 6, 11, 14, 17, 21, 22, 23, 31, 60
  - Broadcast, 15, 18, 23, 26, 27, 45, 50, 51, 52, 59, 60
  - Broadcast through PBX, 50
  - Broadcasting a group of handsets, 26
  - Broadcasting an individual handset, 27
- C
  - Call Conferencing, 18
  - Call Hold, 17
  - Call in-progress, 14
  - Call timers, 17
  - Call transfer, 18, 19, 37, 38
  - Call Waiting, 15, 39, 40
  - Caller ID, 16, 17, 28, 43, 56
  - Cardiac pacemaker, 4
  - Charger Features, 21
- D
  - De-registration, 35, 45
  - DND, 17
  - Do Not Disturb (Silent Ring), 30
  - DTMF, 18
- E
  - Electric shock, 5
  - Equipment Checklist, 11
- F
  - FCC, 7, 8, 9, 64
  - FDA, 4
- Flash time, 19, 44
- G
  - Group ID, 15, 43, 47, 59
- H
  - Handset and charger installation, 22
  - Handset charging slot, 21
  - Handset features, 14, 16
  - Handset Group Subscription, 36, 57
  - Handset ID, 14, 27, 28, 29, 34, 35, 36, 37, 38, 40, 41, 42, 43, 50
  - Handset Registration, 22, 34, 60
  - Handset to Handset Calls, 26
  - Hearing Aid, 4
- I
  - Idle mode, 23
- K
  - KeyGuard, 30, 31, 56
  - Key tone, 17
- L
  - Line Dedication, 43
  - Line Indicator, 14
  - Line Selection, 44
- M
  - Multiple handset registration, 16
- P
  - Phonebook, 45
- R
  - Registration, 34
  - Regulatory Information, 7
  - REN, 64
  - Ringer, 15
  - RSSI, 14
- S
  - Safety Instructions, 4, 6

T  
Speaker phone, 14  
Technical Specifications, 61  
Three Call Logs, 17  
To Call back from Call Log, 31

To View Missed Call(s), 31  
Two-Digit Address Index, 14  
V  
Vibrator, 16

# FCC Part 68 Statement

This equipment complies with Part 68 of the FCC rules and the requirements adopted by the ACTA. On the bottom of DuraFon PRO base station is a label that contains, among other information, a product identifier in the format US: SNIW403BFS2. If requested, this number must be provided to the telephone company.

Applicable connector jack Universal Service Order Codes (“USOC”) for the Equipment is RJ11C.

**A plug and jack used to connect this equipment to the premises wiring and telephone network must comply with the applicable FCC Part 68 rules and requirements adopted by the ACTA. A compliant telephone cord and modular plug is provided with this product. It is designed to be connected to a compatible modular jack that is also compliant. See installation instructions for details.**

The REN is used to determine the number of devices that may be connected to a telephone line. Excessive RENs on a telephone line may result in the devices not ringing in response to an incoming call. In most but not all areas, the sum of RENs should not exceed five (5.0). To be certain of the number of devices that may be connected to a line, as determined by the total RENs, contact the local telephone company. For products approved after July 23, 2001, the REN for this product is part of the product identifier that has the format US: SNIW403BFS2. The digits represented by 0.3 are the REN without a decimal point (*e.g.*, 03 is a REN of 0.3).

If this DURAFON-UHF-HC causes harm to the telephone network, the telephone company will notify you in advance that temporary discontinuance of service may be required. But if advance notice isn't practical, the telephone company will notify the customer as soon as possible. Also, you will be advised of your right to file a complaint with the FCC if you believe it is necessary.

**The telephone company may make changes in its facilities, equipment, operations or procedures that could affect the operation of the equipment. If this happens the telephone company will provide advance notice in order for you to make necessary modifications to maintain uninterrupted service.**

If trouble is experienced with this DuraFon-UHF-HC, for repair or warranty information, please contact:



**Company: EnGenius Technologies, Inc.**

**Address: 1580 Scenic Ave., Costa Mesa, CA 91709**

**Tel no.: 714-432-8668**

If the equipment is causing harm to the telephone network, the telephone company may request that you disconnect the equipment until the problem is resolved.

**Connection to party line service is subject to state tariffs. Contact the state public utility commission, public service commission or corporation commission for information.**

If your home has specially wired alarm equipment connected to the telephone line, ensure the installation of this equipment does not disable your alarm equipment. If you have questions about what will disable alarm equipment, consult your telephone company or a qualified installer.

**WHEN PROGRAMMING EMERGENCY NUMBERS AND (OR) MAKING TEST CALLS TO EMERGENCY NUMBERS:**

- 1) Remain on the line and briefly explain to the dispatcher the reason for the call.
- 2) Perform such activities in the off-peak hours, such as early morning or late evenings.